



# Easy integration – Robotic functionality for packaging processes

ELAU  
Robotic Solutions

The fast path to productivity

ELAU PACKAGING SOLUTIONS

**Schneider**  
Electric

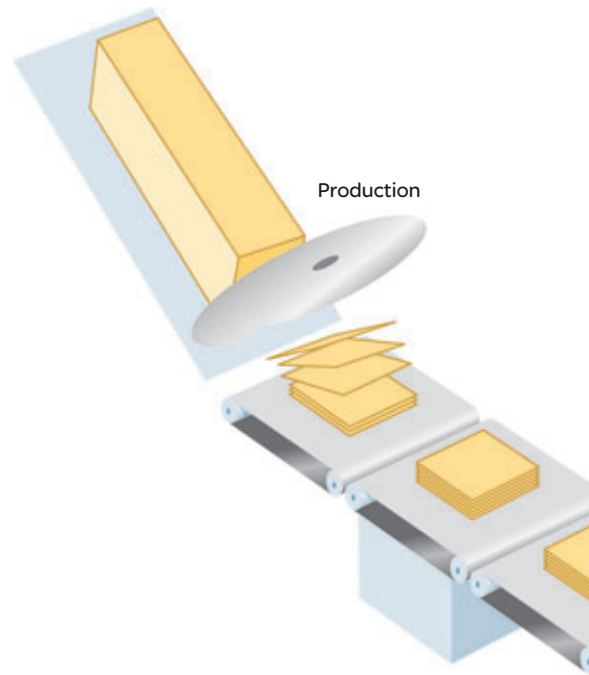

Trend

# Integration of robots into packaging processes

Increasingly, embedded robots and robotic modules are integral to packaging machine design. Robotic functionality provides adaptability to new processes, reduces footprint requirements and even enables the automation of manual tasks.



## Case Packer with a delta 2 robot

Robotic vertical case packer has become increasingly popular.

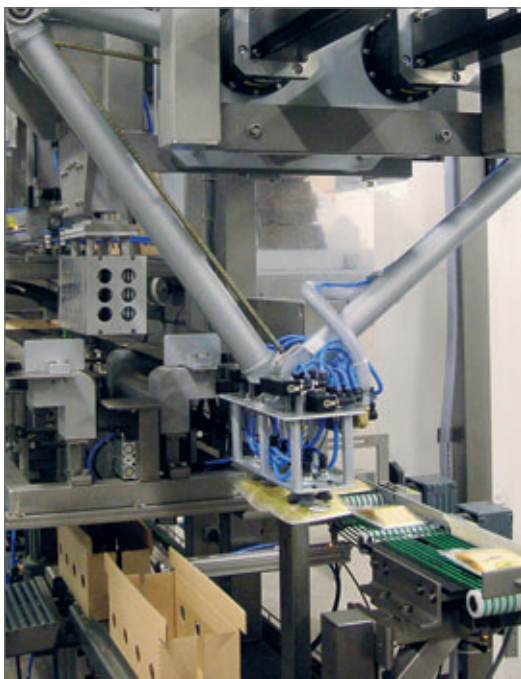

## Faster changeovers by eliminating format-specific change parts

Robots add flexibility to packaging processes. Changeovers can be programmed by entering new parameters, with pushbutton, recipe driven changeovers then selected by the operator at the human machine interface (HMI). Without or with only minimal end-of-arm tooling changes, robotic modules can reduce setup times to variously sort, orient, pick & place, fill and de-case a broad range of product and package types.

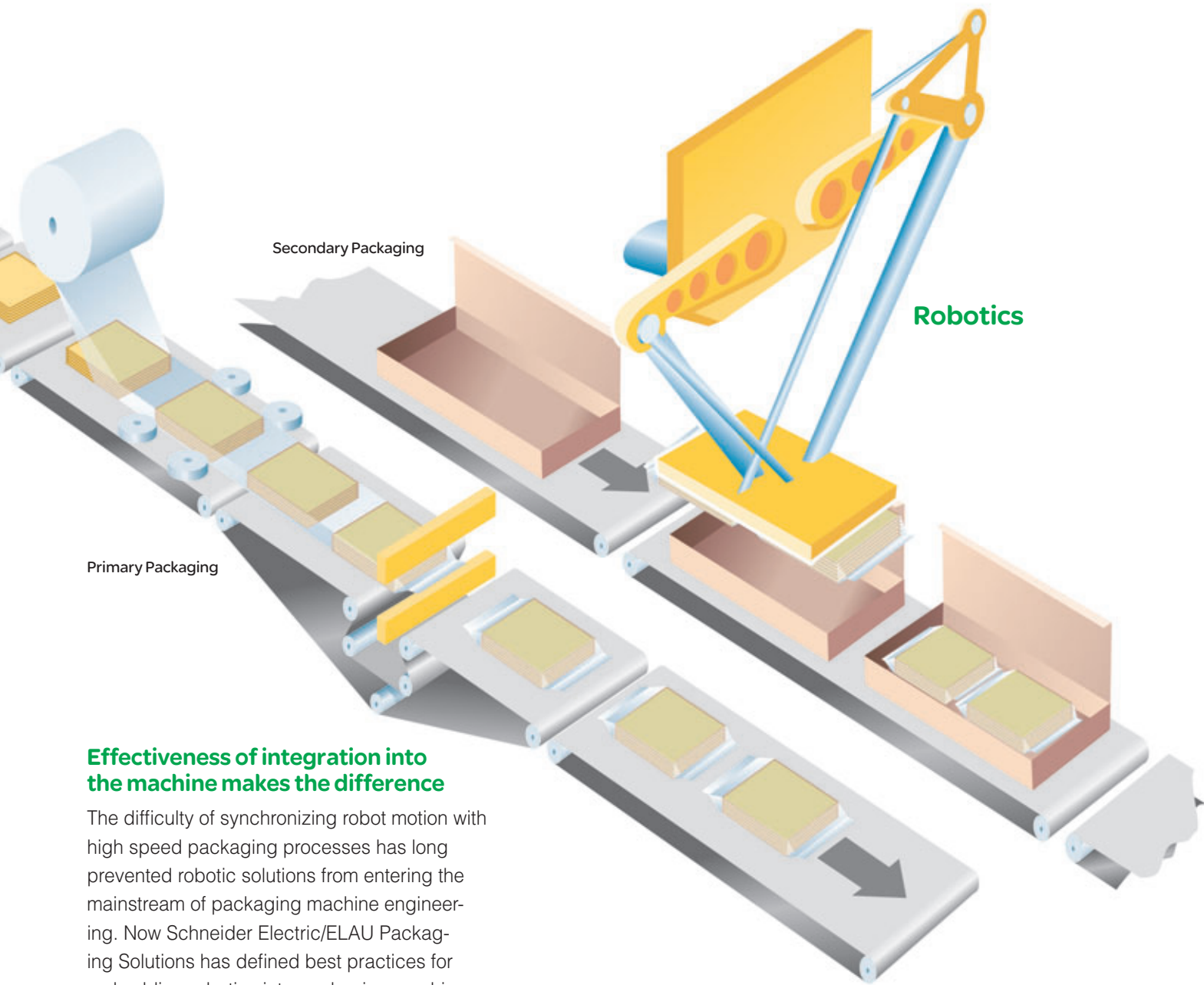

**Effectiveness of integration into the machine makes the difference**

The difficulty of synchronizing robot motion with high speed packaging processes has long prevented robotic solutions from entering the mainstream of packaging machine engineering. Now Schneider Electric/ELAU Packaging Solutions has defined best practices for embedding robotics into packaging machine automation.

Conventional

# Two worlds of control collide

Most conventional robot systems use proprietary controllers that require communications software and network interfaces to integrate with the machines' PLCs and motion controllers. Therefore, the real-time synchronization of robots and machines can prove problematic, especially considering the throughput required by food, beverage and other consumer packaged goods manufacturers.

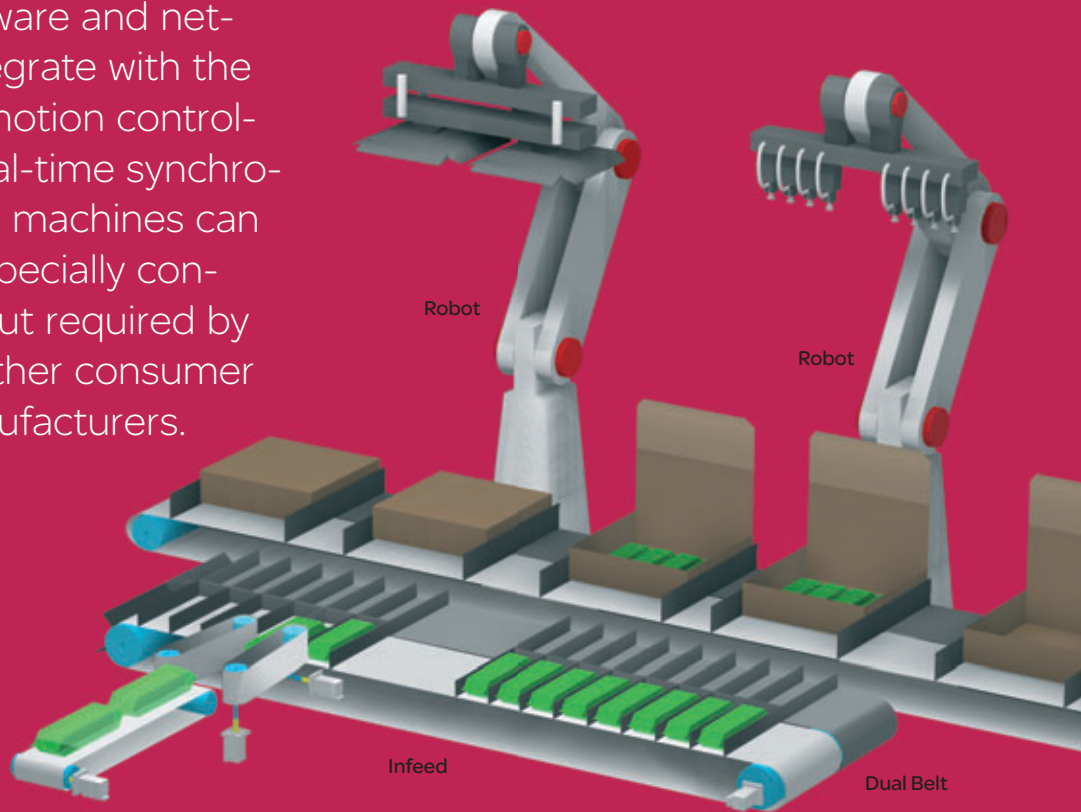

## Disadvantages of conventional solutions

- Additional proprietary robot controller
- Different programming languages
- Extensive synchronization effort

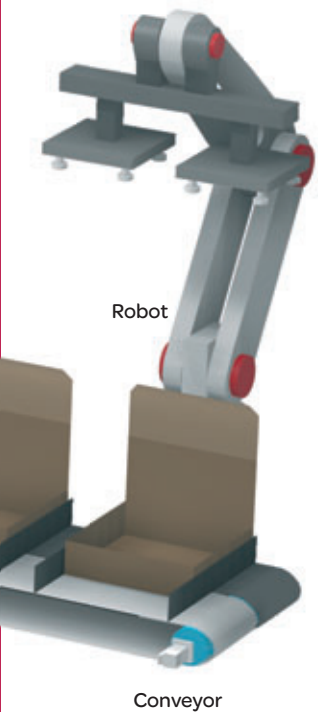
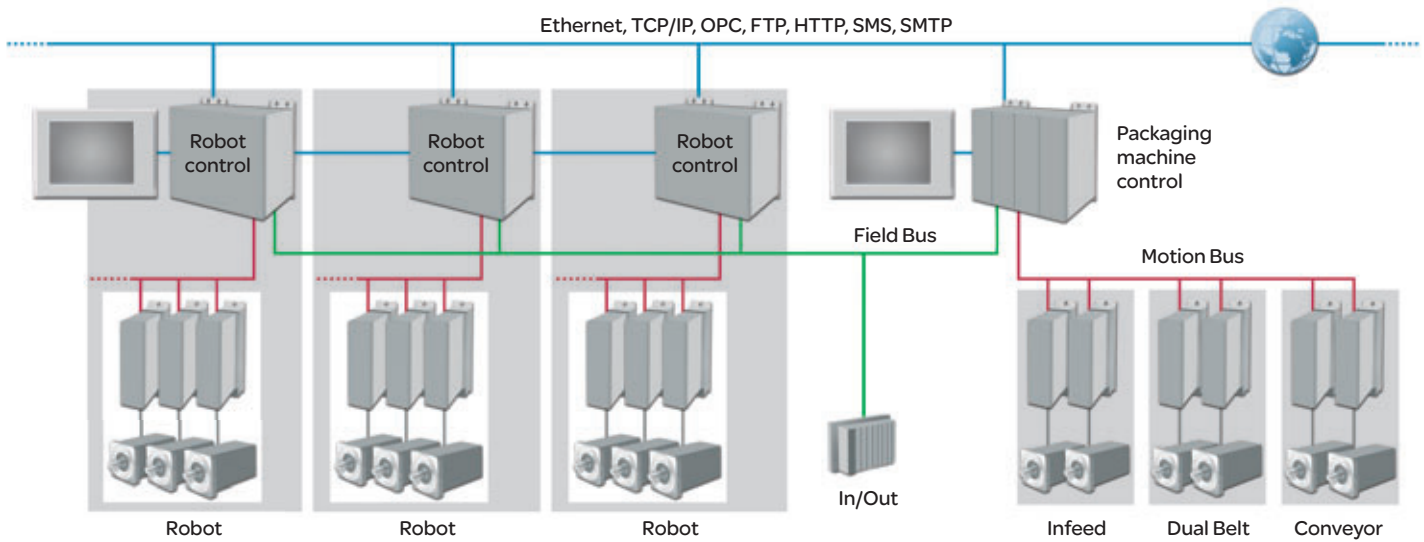

### Integration of two different controllers

Integrating a proprietary robot controller into a machine's control system does not promote flexibility or high reliability. It requires a different language, additional programming and communications hardware.

The communications become a bottleneck, reducing throughput and impacting response time.

This is a significant drawback that can compromise the very productivity gains that robot technology was intended to deliver.

Innovative

# Robot and machine automation integrated in one control

Until now, it was impractical to run multiple, complex robots and highly dynamic packaging machinery simultaneously from a single controller. Schneider Electric has now made it practical to control packaging machines and up to thirty robots using a single, IEC 61131-3 compliant ELAU automation controller.

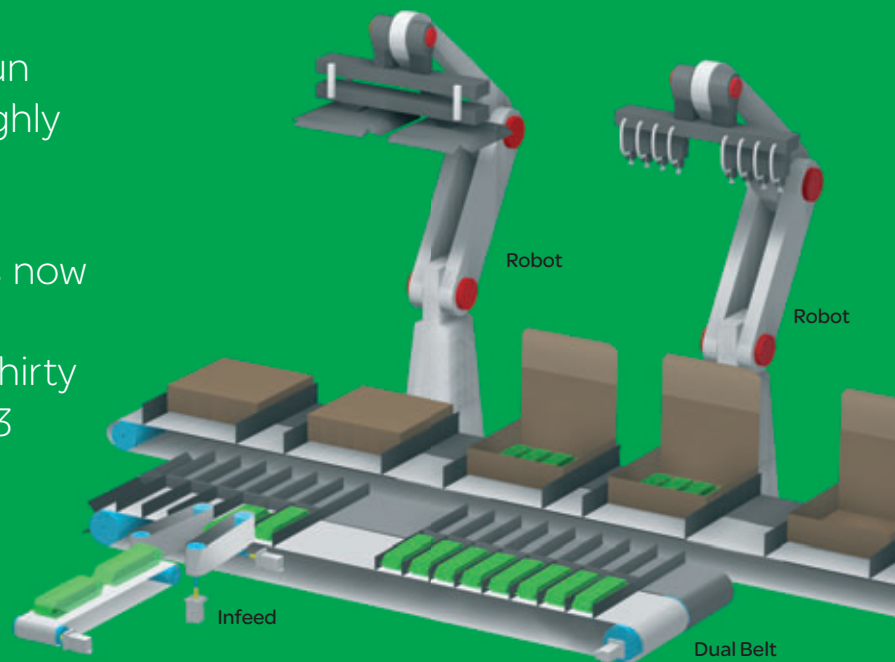

## Benefits of the ELAU solution

- Reduced engineering and training
- Reduced hardware costs  
(No proprietary robot control)
- Fewer interfaces, easier service
- One control concept  
for packaging machine and robot

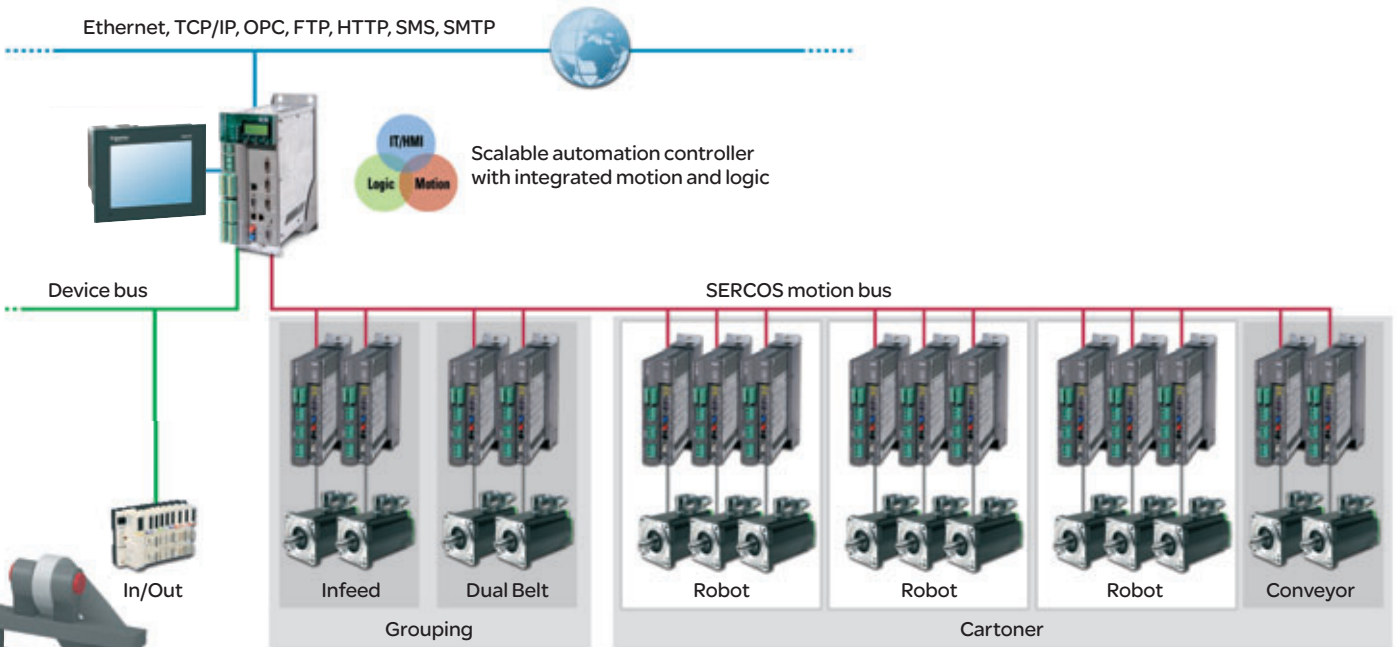

### Robots integrated as equipment modules

Impressive hardware performance is inherent to the ELAU control platform. That's how motion, PLC logic, HMI, vision, communications and IT data acquisition interfaces can be integrated in a single controller.

As a result, electrical cabinet space is reduced, and hardware costs are considerably lower. At the same time, overall system performance can be significantly improved.

### Performance table for robot applications

Robot type	Number of dimensional axes	Number of robots per C600 controller*	
		With Move command	With Move command and ACC-Limit**
Portal	3	30	7
Gantry	2	30	7
Articulated	3	10	6
SCARA	2	10	6
Delta	2	10	6
Delta	3	8	6

Subject to modifications

\* Maximum values, the actual number of robots per controller may be smaller depending on accuracy and velocity requirements

\*\* Intelligent acceleration monitoring

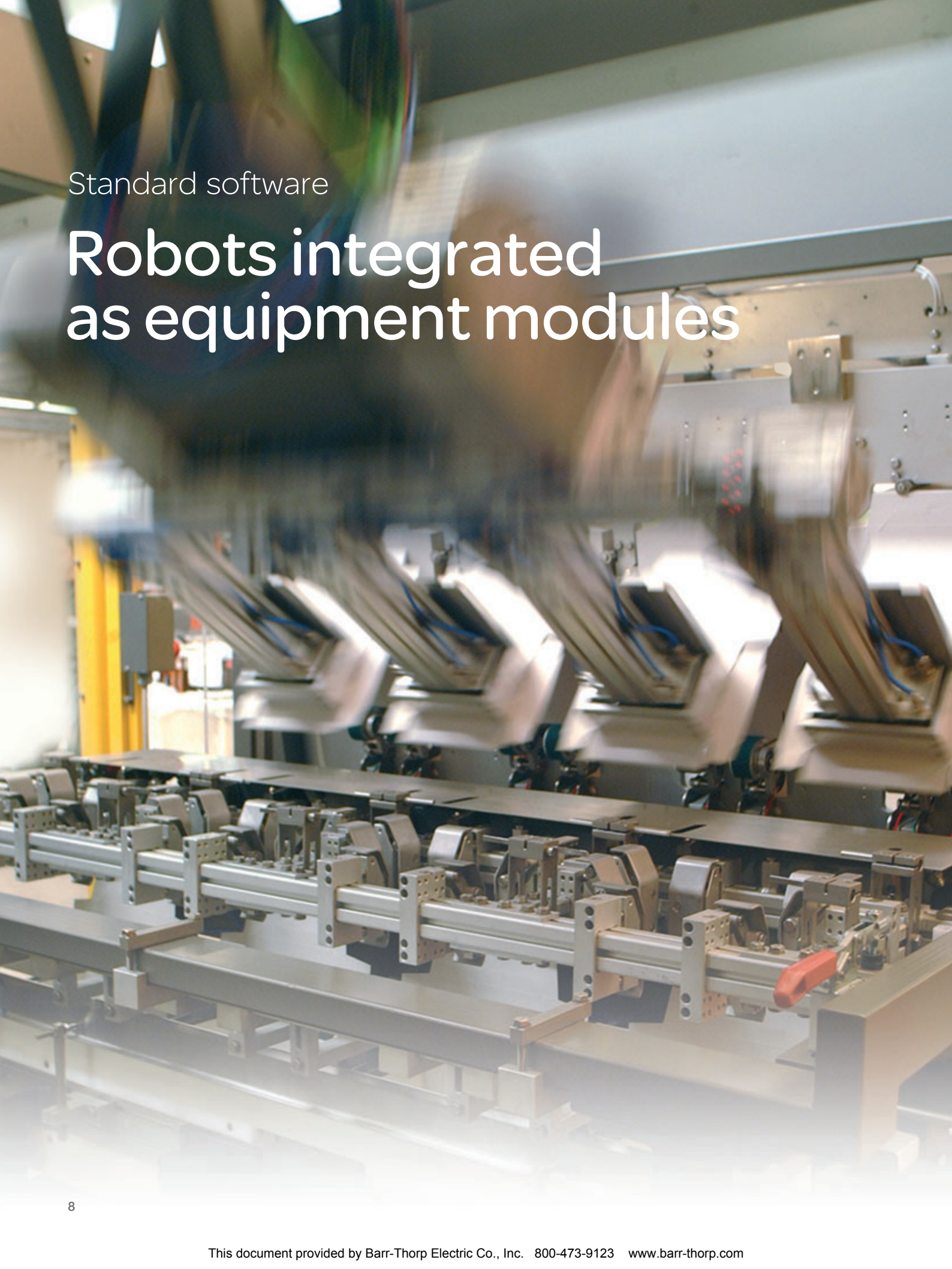

Standard software

# Robots integrated as equipment modules



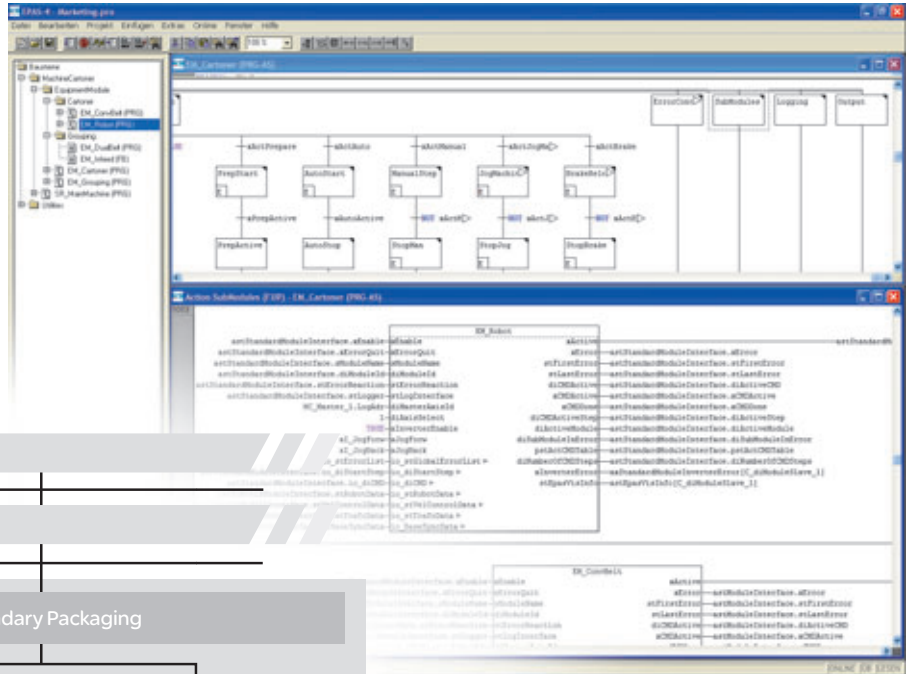

MES/ERP Level

Line Level

Machine Level

Equipment  
Module Level 1

Equipment  
Module Level 2

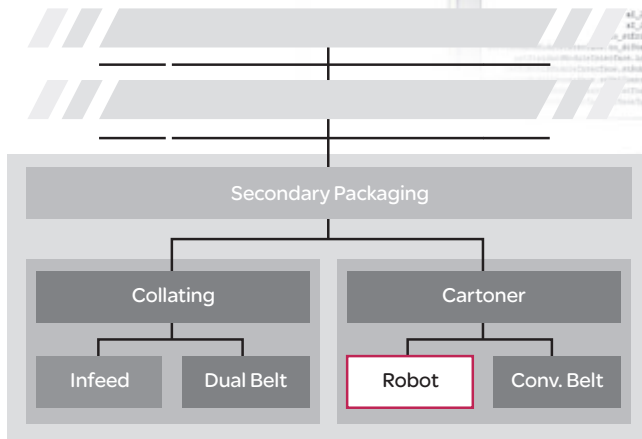

**EPAS-4**  
automation toolkit:  
Integrated robotics

Using a programming template, the robotic module can be integrated into the overall application just like any other machine module. The learning curve is short, so the program developer can focus on programming the actual motion tasks.

### Modular software structure with the ELAU template

It doesn't take a lot to integrate multiple robots in a project. Access to variables also simplifies engineering and diagnostics. And programming is simplified by an extensive library of IEC 61131-3 conforming function blocks, including the PLCopen and ELAU motion control function blocks.

ELAU's experience integrating robotic functionality into packaging machinery demonstrates that engineering, commissioning and service tasks can be significantly reduced.



- Easy programming and diagnostics with the integrated EPAS-4 automation toolkit – including robots
- Convenient access to variables
- Virtually no additional software tools
- Avoid duplicated training courses

# Fast integration through a function block library

The clearly structured programming concept is based on a function block library. Just program start and end points once, and it works automatically with your robot configuration.



- Controller performs path planning - just specify start and end points
- Change robot types with minimal effort
- No need to program each axis - so format changes are easier with robots
- Avoids crashes, because path is not impacted by velocity or acceleration changes
- High quality software solution and shortest possible engineering times

Standard interpolation types – including spline, linear, point-to-point and circular interpolation – can be selected. Special functions for Pick & Place applications reduce cycle and engineering times. Special functions for Pick & Place applications reduce cycle and engineering times. Next, the blending parameters, an important factor to optimize trajectories and shorten cycles, are defined. Parameters for both the value and direction of the maximum permissible acceleration (g force) on the product at the tool center point (TCP) can also be set.

Other tasks are performed by the kinematic transformation software module in the controller. It converts the Cartesian coordinates into the individual robot axis position commands. Integrated acceleration monitoring helps ensure that the centrifugal force at the TCP does not exceed the set parameters. Each product is transported over the optimized distance in an efficient amount of time, even if product infeed is random.

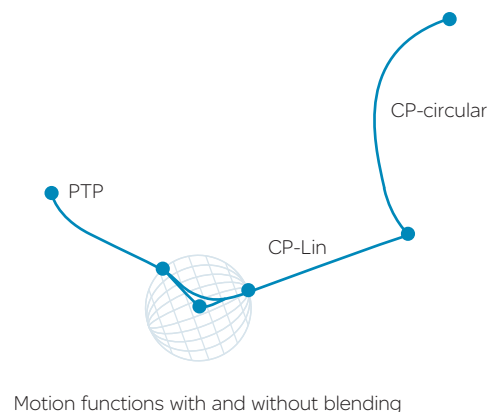
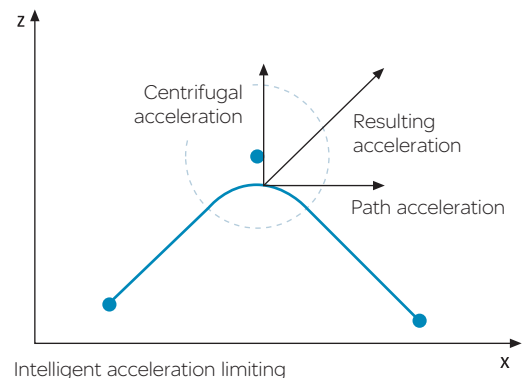

Implementation steps

**Cartesian programming of the trajectory**



**Optimization**



**Automatic transformation**



**Generation of multi-axis movements**



**Drive control**

**User effort**

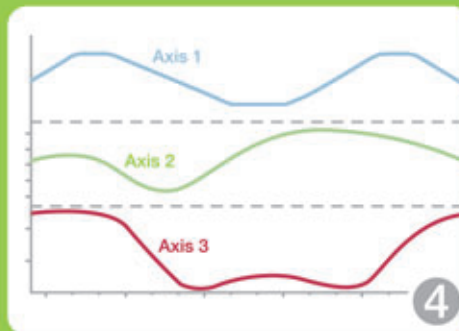
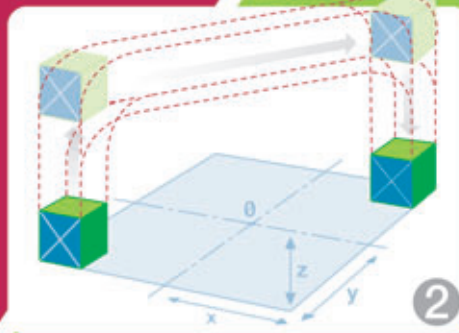
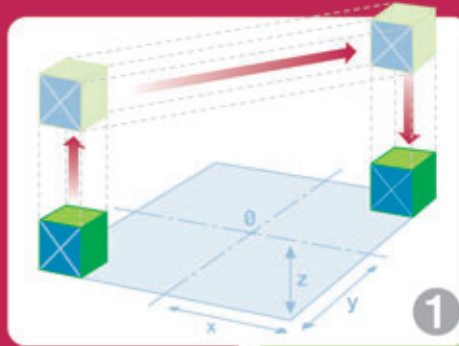

**Automated operation by the controller**



**Specify trajectory by program or table:**

- Linear
- Circular
- Spline
- Point-to-Point



**Optimize velocity in context of physical limitations:**

- Blending
- Intelligent acceleration limiting



**Parameterize transformations by application:**

- Delta
- SCARA
- Articulated
- Gantry
- Portal



**Automated on-the-fly calculation and adaptation of the individual axis profiles necessary for the Cartesian trajectory**



**Robotic motion achieved**

## Conveyor Tracking

# Product infeed with virtually any number of belts

Robots can be synchronized with one or several belts by simple commands. Theoretically, a robot can be synchronized with up to 99 belts, whether indexed or continuous – even with variable velocities.

The software to control belts and robots is embedded in a single program in a single controller. The resulting short interpolation cycles facilitate fast, accurate response to change.

This also represents a substantial cost benefit. Synchronization and referencing don't require external feedback signals, eliminating discrete components – encoder, encoder cards, a separate device, possibly a PLC – and certainly engineering and installation costs.



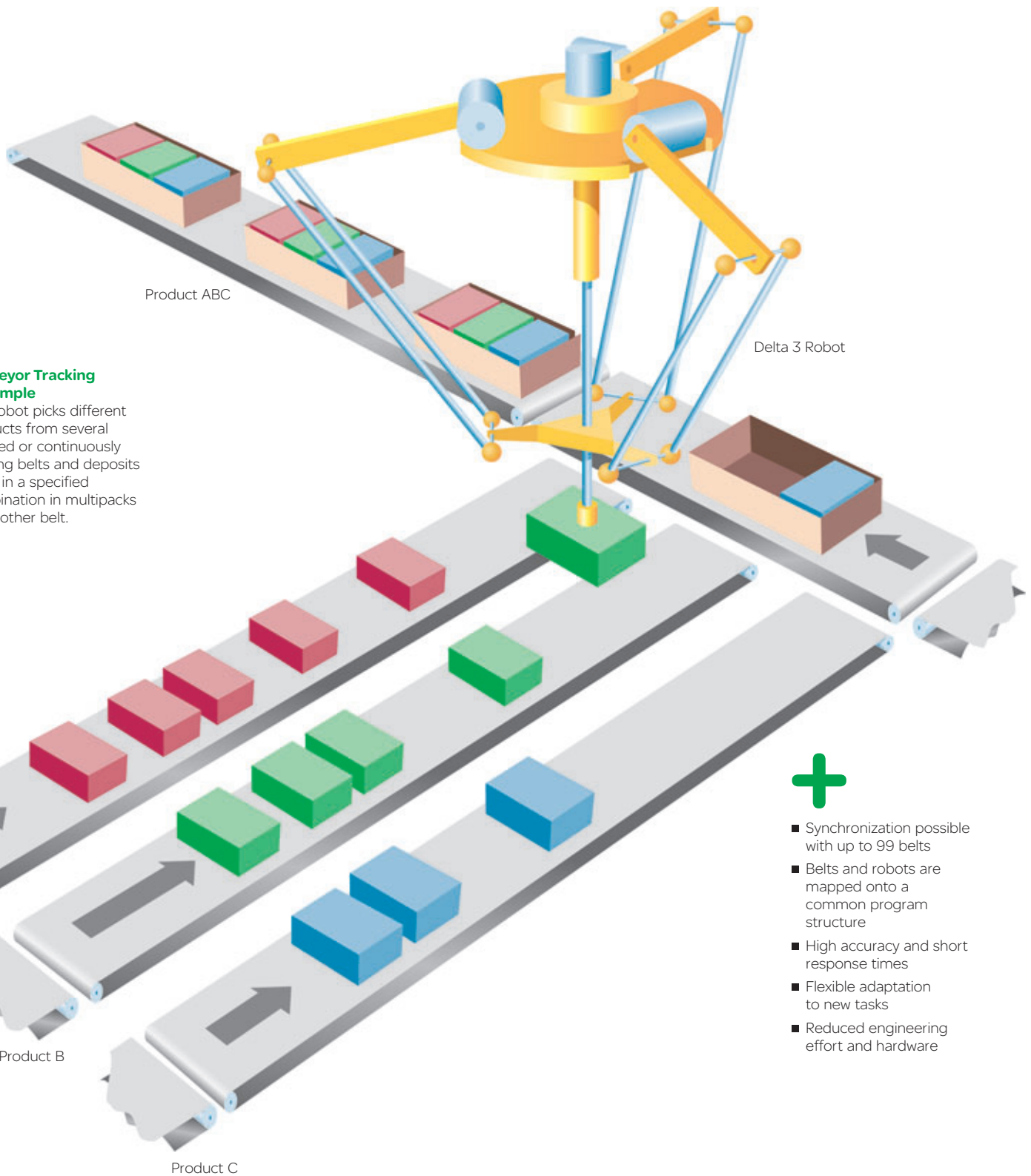

**Conveyor Tracking  
- Example**

The robot picks different products from several indexed or continuously running belts and deposits them in a specified combination in multipacks on another belt.

Delta 3 Robot

Product ABC

Product A

Product B

Product C



- Synchronization possible with up to 99 belts
- Belts and robots are mapped onto a common program structure
- High accuracy and short response times
- Flexible adaptation to new tasks
- Reduced engineering effort and hardware



Vision

Bread, meat, confections.  
Round, rectangular,  
color sensing ...  
... what do you need to pack?

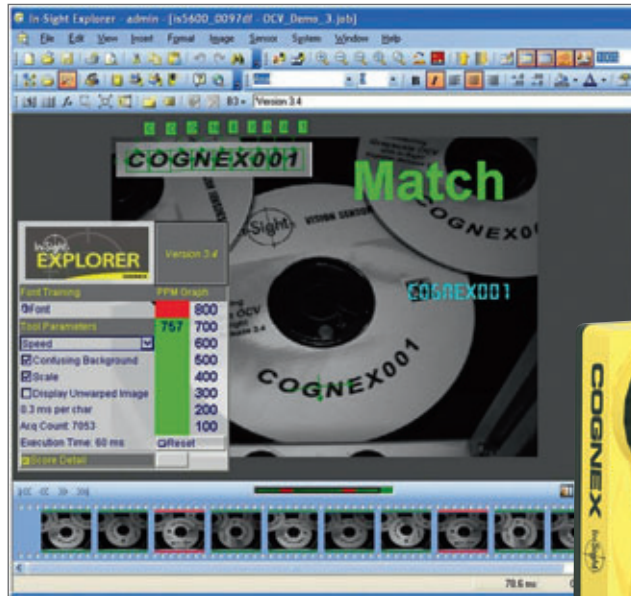

**As easy as can be:**  
An equipment module minimizes the integration effort for Cognex In-Sight 5000 series image processing systems.

What would robots be without high efficiency vision systems? They are key to the transition from static to continuous product infeed. They make the packaging process more efficient and flexible, and new applications become possible.

**Use a vision system or choose an integrated solution**

Vision systems enable robots to pick products with non-uniform shapes, randomly fed from belts, and to place them with consistent accuracy in packages. Or, they can pick specific products from mixed product flows.

ELAU robotic solutions accommodate vision guidance. Virtually any vision system on the market can be integrated. But a pre-programmed equipment module makes integration of the popular Cognex In-Sight 5000 series as easy as any ELAU system component. It only requires parameterization to communicate the required coordinates to the ELAU controller. And it happens in real-time, without additional hardware or programming.



## Kinematics

# Third party or ELAURobotics: Standard kinematics for packaging applications

The ELAU control system performs the kinematics for standard robot configurations, including articulated, gantry, delta, SCARA, and portal robots in up to six dimensions. The robotic library provides transformation modules that can be mapped onto the machine software in keeping with the principle of modularity.



- Configurable transformation modules for standard kinematics
- Universal transformation module for customer-specific kinematics
- Function blocks for each robot type; so they can easily be interchanged with no impact on the rest of the machine control software
- ELAU delta 2 and delta 3 mechanics facilitate the changeover to robotics
- Available engineering services get you up to speed fast on robotics

To switch to a different robot type takes only a change of the transformation module. The rest of the machine's software program remains untouched. And it doesn't matter if the robots are customer-specific designs or commercially available mechanical systems – as long as they can be adapted to ELAU servo drives, an ELAU robotic automation solution is possible.



The integration is even simpler with robot mechanics from ELAU. These delta 2 and delta 3 kinematics are purpose-built for packaging applications to facilitate machine builders' transition to robotics.

The benefit is a proven solution that does not require kinematic skills. Everything fits, everything comes from one source – mechanical components, motors, control, software, and spare parts. The solution includes plug-and-play vision systems by market leader Cognex. In addition to the mechatronics technology, we also offer engineering services – a fast way to get up to speed on robotics.



**Open for every solution**  
Standard kinematics,  
customer-specific or an  
ELAU mechanical solution  
– ELAU supports standard  
kinematics





Delta 2

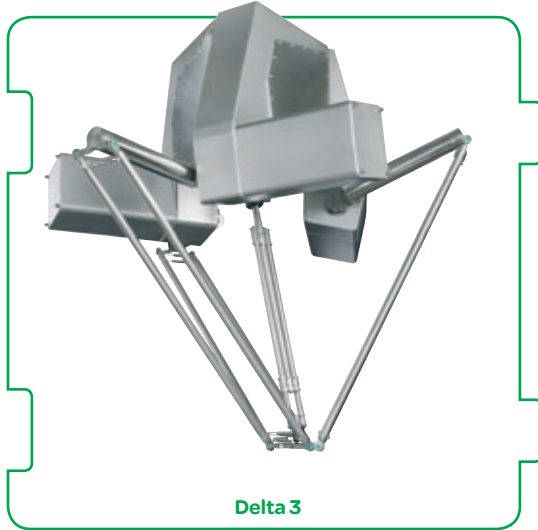

Delta 3



Delta 2 and delta 3 robot arms are also available from ELAU as ready-to-run mechanical solution packages

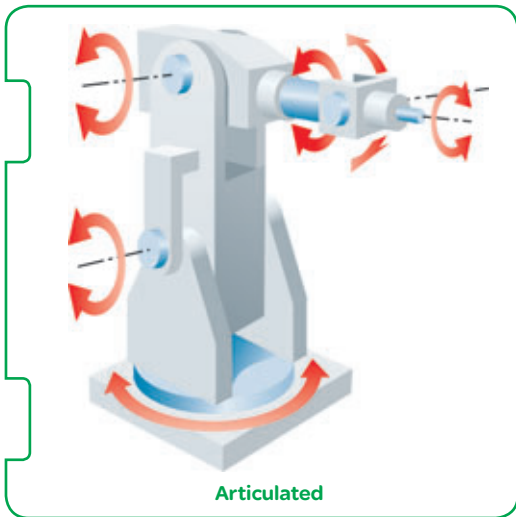

Articulated



Portal



The MAXR gantry robot is available from Schneider Electric in two versions with two or three axes, plus an optional rotary axis

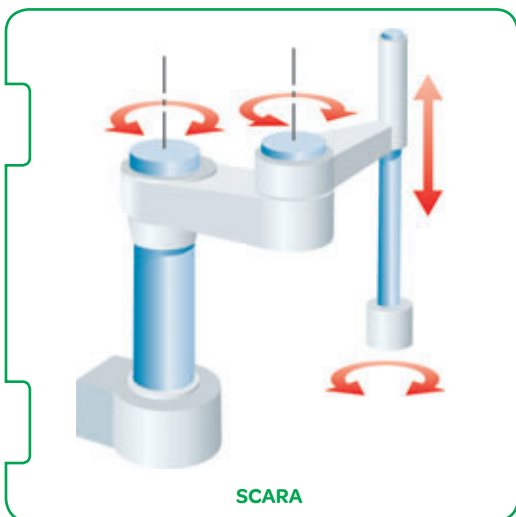

SCARA

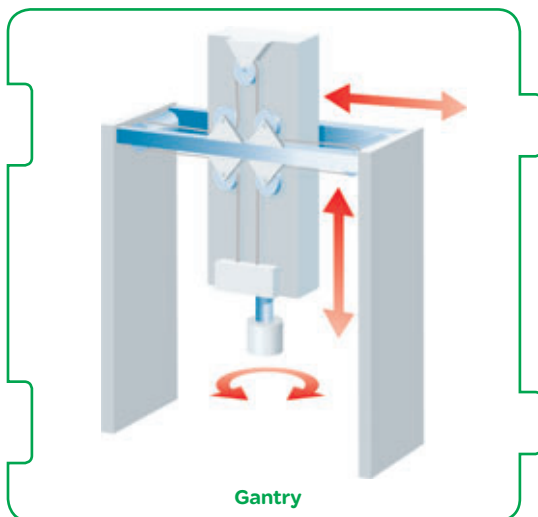

Gantry

For controlling robots with ELAU controllers, the developer can choose between configuring transformation modules for standard kinematics from pre-tested function blocks, or developing their own intellectual property, using ELAU's universal transformation module.

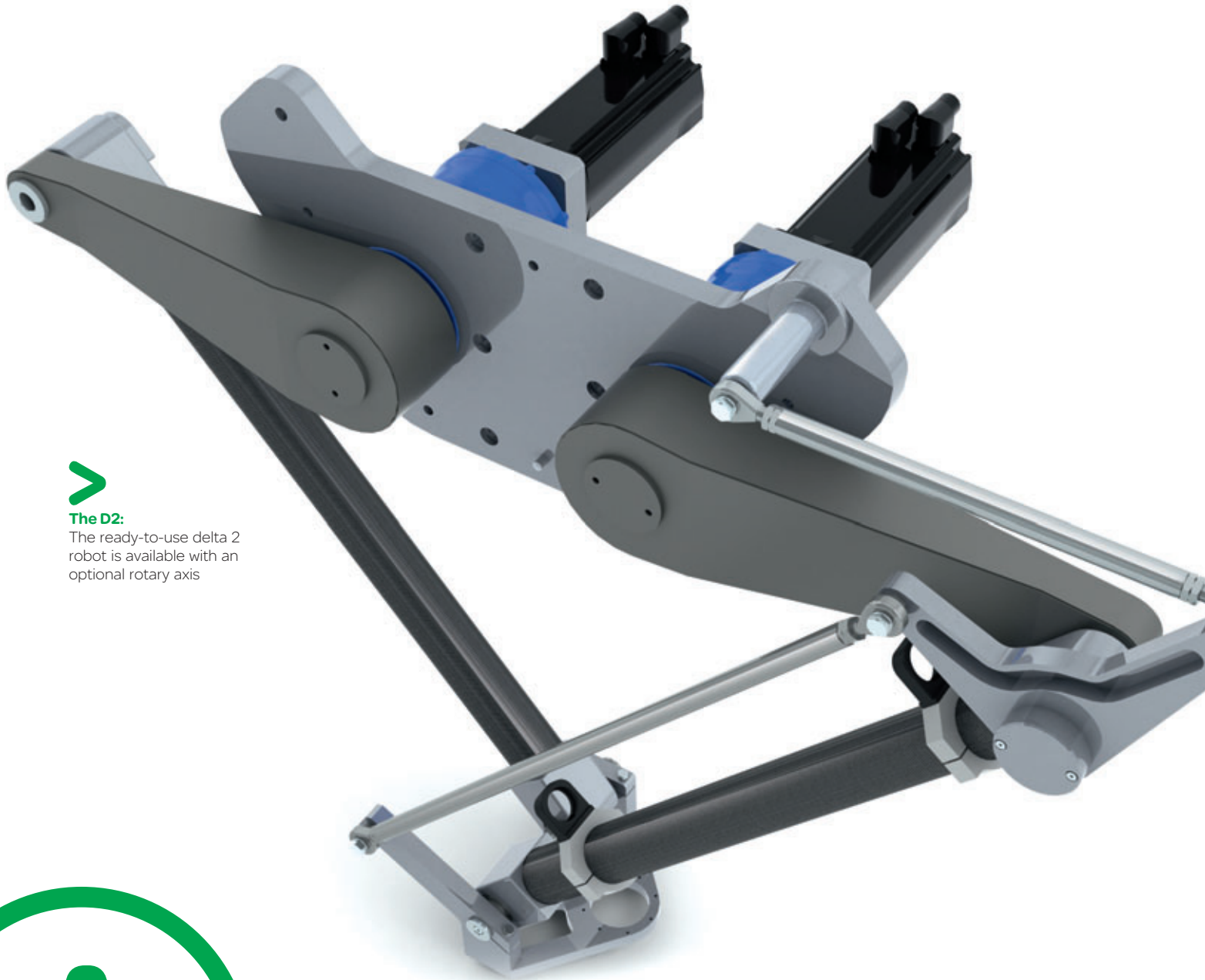

**The D2:**

The ready-to-use delta 2 robot is available with an optional rotary axis



- High payloads and large work envelope
- Flexible integration of the D2i by iSH servo module with integrated servo drive

## ELAU Robot D2

# Simple, innovative and vertical! The D2 is ideal for top-loading applications

The D2 is a delta 2 robot ideal for various pick & place and vertical packing processes. Especially for case/tray packers and multipackers, top loading solutions are the trend. They offer high flexibility in product and packaging while saving valuable space with their small footprint.

The D2 is quick, quiet and reliable. Its maximum load capacity is 25 kg or 55 lbs.

The D2s-F model uses conventional SH servo motors with cabinet-mounted servo drives. Though mechanically identical, the D2i-F model offers the benefits of iSH servo module technology.

Servo modules integrate the drives on the motors, significantly reducing cabinet space and cabling with only a shared power supply inside the cabinet for up to 25 machine-mounted servo modules. Servo modules are connected via single cable from the cabinet to machine-mounted distribution modules and single, quick connect cables to each servo.

The D2 is also available with an optional rotary axis (model D2s-R or D2i-R).

### Performance

Type	D2s-F/D2s-R	D2i-F/D2i-R
Number of axes	2-3 (rotary axis)	
Load capacity	25 kg	23 kg
Robot weight	85 kg	90 kg
Work envelope	1000 mm x 360 mm	
Maximum cycle rate	70 cycles / minute	
Repeatable accuracy	< 0.5 mm	
Typical applications	Case packing Tray loading Pick & Place	

Subject to modifications



**Practical experience:**  
The D2 has already proven itself in a variety of secondary packaging applications



**The P4:**

Delta 3 functionality,  
available in washdown  
configuration for hygienic  
environments



- IP-65 rated, sealed stainless steel design for pharmaceutical and food applications
- Optimized tube/cable mounting through the parallel plate reduces risk of collision with products and machine parts
- Available with iSH servo modules for non-washdown applications



## ELAU Robot P4

# High speed robot for pick & place applications

The P4 is a delta 3 robot designed for fast pick & place operations. It sets itself apart through short cycle times and an exceptional payload capacity of up to 1.5 kg. Combined with a vision system, the P4 can also be used for random and/or mixed product flow picking.

The robot's mounting fixtures are at the very top, reducing the risk of the robot arms colliding with the frame, even at extreme deflection.

The P4s-F model uses conventional SH servo motors with cabinet-mounted servo drives. It is IP-65 rated for use in washdown environments.

The P4i-F model uses iSH servo modules. Servo modules integrate the drives on the motors, significantly reducing cabinet space and cabling with only a shared power supply inside the cabinet for up to 25 machine-mounted servo modules. Servo modules are connected via single cable from the cabinet to machine-mounted distribution modules and single, quick connect cables to each servo.

The P4 is available with an optional rotary axis (P4s-R or P4i-R).



P4s (wash down)



P4i (with iSH servo drives)



Rather than a rotary union that accommodates only one tube, the P4 provides guide holes in the robot's parallel plate (the end effector mounting plate) for multiple tubes or wires, which remain protected within the plate. Today's sophisticated grippers require multiple pneumatic tubes with sufficient length to support rotation. In conventional designs, these tubes must be routed around the outside of the parallel plate, where they can interfere with processes or collide with products. The innovation of guiding tubes and wires through the parallel plate reduces the risk of collision with surrounding objects, and allows optimal use of the horizontal work envelope.



With its sealed drive housing, the P4s with standard drives (left) is designed for hygienic environments; the P4 with intelligent servo modules provides cooling slits for heat dissipation in non-washdown applications.

### Performance

Type	P4s-F / P4s-R	P4i-F / P4i-R
Nominal ultimate load	1.5 ** [kg]	
Maximum speed	10 [m/sec]	
Maximum acceleration at 1kg	100 [m/sec <sup>2</sup> ]	
Maximum acceleration at 1.5kg	75 [m/sec <sup>2</sup> ]	
Number of axes	3 (4*)	
Repeatable position accuracy	+/- 0.1 [mm]	
Work envelope height	225 / 350 [mm]	
Work envelope diameter	1200 / 750 [mm]	
Work envelope rotation	unlimited	
Protection rating	IP 65	-

Constantly updated data available at [www.elau.com/robotics](http://www.elau.com/robotics) Subject to modifications

\* including rotary axis in the R version

\*\* Up to 3.5 kg possible with special configuration, please contact us.

## Application examples

# 'Mixing possible' – making rainbow packing more efficient

With retail shelf space at a premium and the market demand for greater product diversity, there is increasing need for variety packs. What appears to be a simple task is in reality a labor intensive process that has defied automation until now.

A good example of the use of robots for packaging mixed or rainbow packs is the packaging line developed for the food industry by Vepatec Verpackungstechnik GmbH. Different products are conveyed in open cases on parallel belts. A D2 robot on each belt de-cases the products and deposits them on a parallel running belt which leads to a mixing station where assortments are merged according to specifications.

Downstream, another D2 packs the assortments back into cases. Up to 150 multipacks leave the line per minute.

Incredibly, a single ELAU controller controls the infeed and transport belts as well as the mixing station and the four toploding robots. In a conventional system, each robot would require its own proprietary controller interfaced to PLCs and motion controls for the material handling and mixing systems. It doesn't take an automation expert to recognize the power and simplicity of this powerful hardware and software platform.

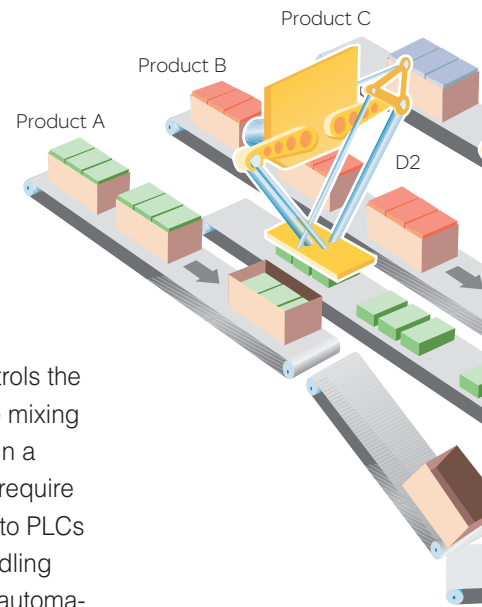



**Three D2 de-casing robots:**

View of the mixing station developed by Vepatec, here the staggered layout of the D2 robots de-casing unmixed products

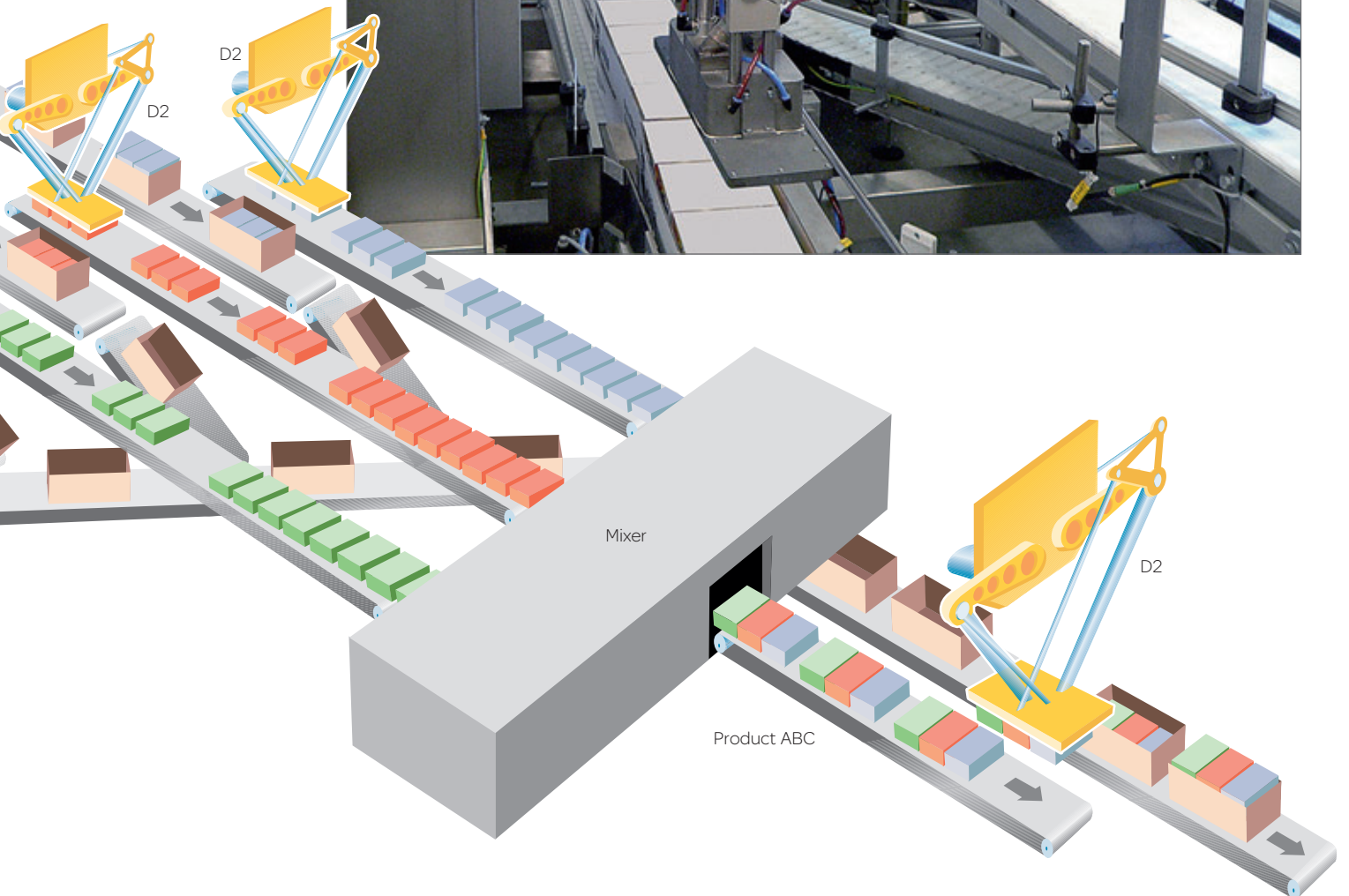

Application examples

# ELAU – for many, the right solution



pester pac automation  
PEWO-pack 450

pester pac automation

## Compact shrink wrapper with integrated robotic product orientation

“The pac robot could not have been developed without ELAU’s robotics library. Because ELAU covers all the system functions, we can concentrate on our core competency, namely product handling in the packaging process.”

**Lorenz Fleschutz,**  
Software Engineering Department Manager

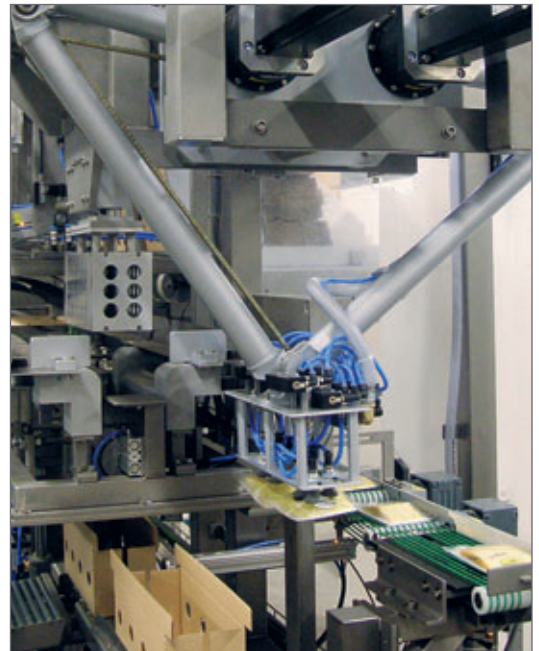

Wächter Packautomatik

## Case packer with dynamic pick & place robot

“ELAU’s robotic functionality and program structure enabled us to cut our engineering and commissioning workload by around 25%. At the same time, we doubled the picker’s output from 30 to 60 transfers per minute.”

**Stefan Wächter,**  
Chief Executive



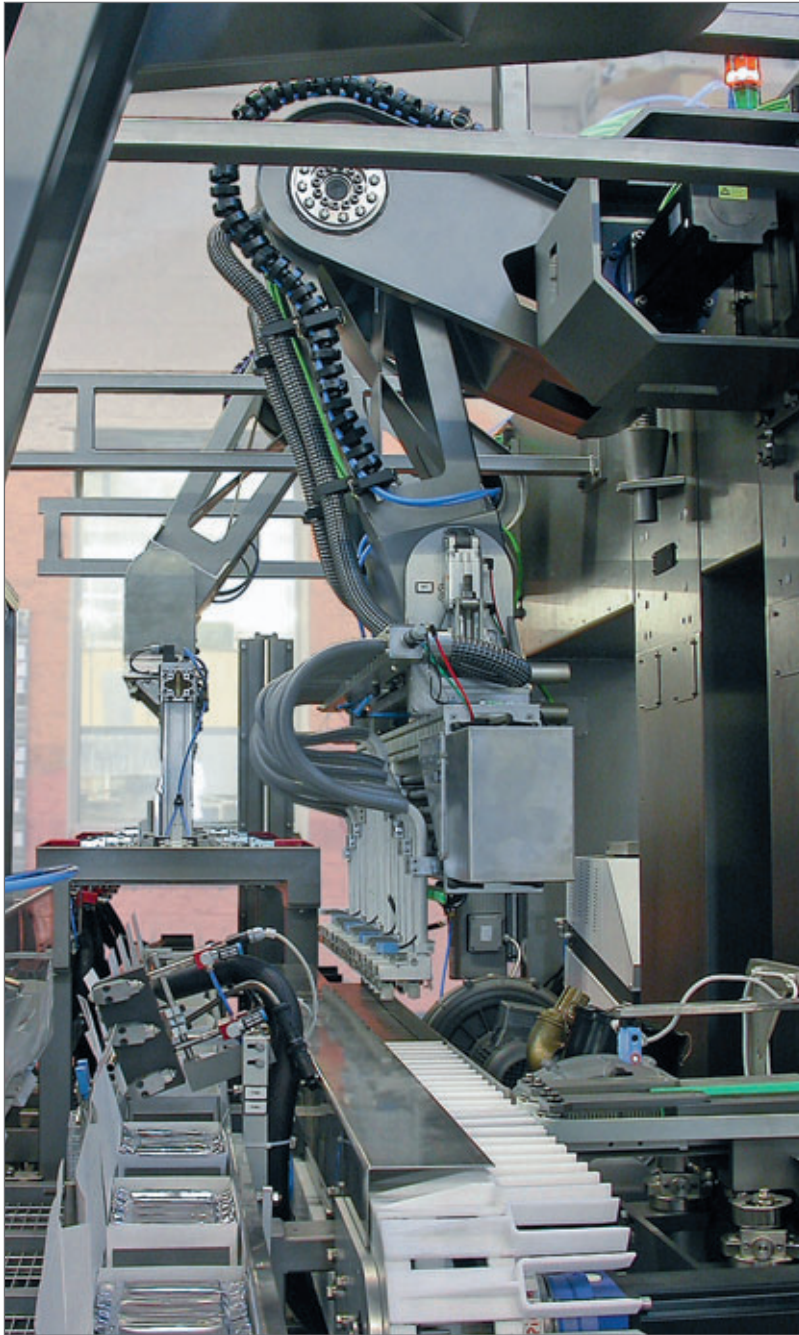

Cavanna

**Robotic vertical cartoning machine (including infeed, dual belt, 3 robots, conveyor belt)**

“The ELAU solution means that we can easily integrate several robotic modules into the packaging application. The machine modules are controlled by a single ELAU controller and programmed using a standard software tool.”

*Riccardo Cavanna,*  
CEO

Cavanna, Cartesio G35

Buhmann Systeme

**Vertical cartoner with mixing and sortation station, two pick & place robots**

“The modular software concept precisely reflects our pursuit of modular machine designs.”

*Robert Vetter,*  
CEO



Benefits

# One system

**– The benefits  
at a glance**



## Control of packaging machinery with multiple robot modules in a single controller

- Reduced engineering effort
- No separate robot controller
- Reduced hardware costs
- Single, cohesive system with no complex interfaces
- Less electrical cabinet space required
- One operating concept for packaging machine and robot
- No additional software tools and simplified training
- Supports standard robot kinematics: gantry, SCARA, portal, articulated, delta
- Convenient access to process variables
- Modular software structure using the ELAU template

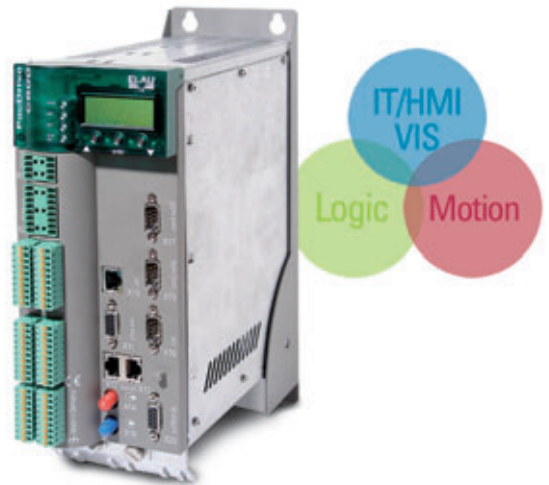

## Comprehensive system solution – including robot mechanics

- Perfectly matched components
- Purpose-built for packaging, from Schneider Electric/ELAU Packaging Solutions
- Mechanical solution packages available for delta 2, delta 3 and portal robots
- Turnkey solution – hardware & engineering – for fast adoption of robotics





# Contact

Please note that the information expressed in this document is intended for product description purposes only and is not legally binding. The information is subject to change without further notice. If details from this document become express terms of a contract concluded with ELAU, the details from this document referred to in the contract are intended only for the specification of the subject of the contract.

ELAU is a registered trademark of Schneider Electric and/or its affiliates in the United States and/or other countries. Other marks used herein may be the property of their respective owners.

© 2010 Schneider Electric.  
All rights reserved.

ELAU GmbH  
Headquarters  
Dillberg 12-16  
97828 Marktheidenfeld,  
Germany  
Phone +49 9391 606-0  
Fax +49 9391 606-300  
info@elau.de  
www.elau.de

[www.elau.de](http://www.elau.de) · [www.elau.com](http://www.elau.com) · [www.elau.it](http://www.elau.it) · [www.elau.fr](http://www.elau.fr)